



SDLB 系列精密蜗轮蜗杆减速器
SDLB SERIES HIGH PRECISION WORM GEAR UNITS



回转间隙可达 **1** 弧分
Backlash down to **1** arc minute

SDLB 减速器是精密行星减速器的理想替代产品，设备厂商可以大幅减少使用精密行星齿轮减速器的应用成本

SDLB series high precision worm gear is an ideal substitute for precision planetary gearbox, the equipment manufacturer can substantially reduce the cost of using precision planetary gearbox

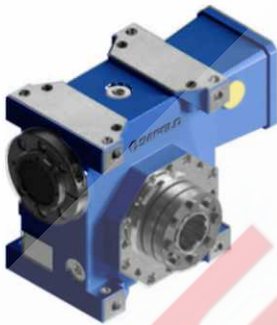
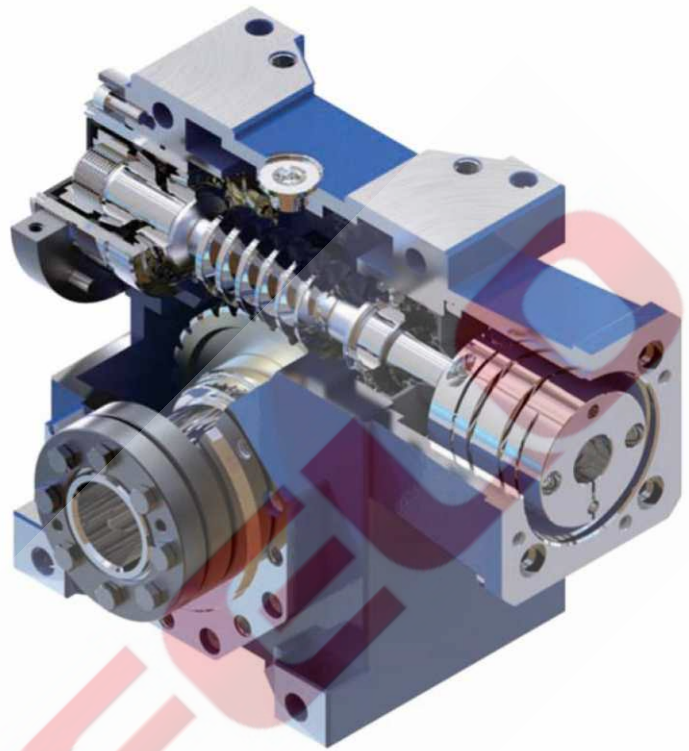

具有收缩盘的空心轴输出，精度高，容易整合
Hollow output with shrink disc, high precision, for easy integration

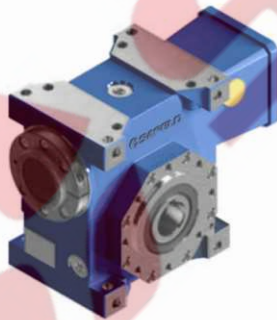

带键孔输出，安装方便，容易整合
Output with keyway, convenient installation, easy integration

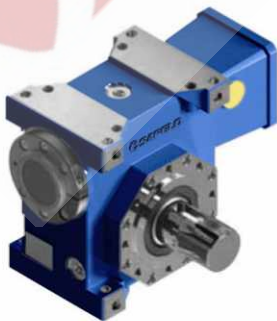

实心轴输出（单、双出轴），刚性好，传统方式
Solid shaft output (single, double), high stiffness, traditional solution

设计者的理想解决方案是旋转
90° 来安装伺服电机驱动系统
The designer's ideal solution
is to rotate 90 degrees to
install the servo motor drive
systems

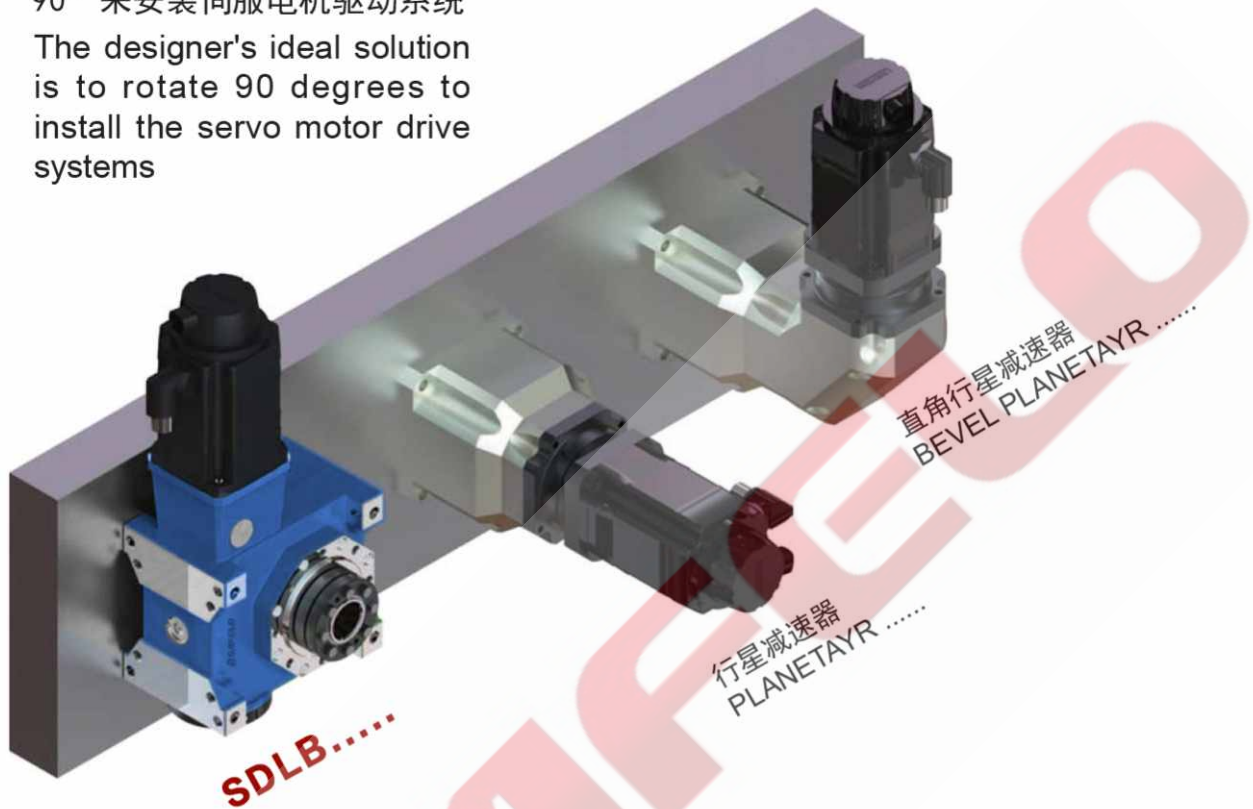

蜗杆（输入）可以串联由一个电机驱动，实现多个蜗轮同步输出。可配套使用于各种电子、通信行业零部件的加工设备

Worm shaft in series can be driven by one motor to achieve synchronous output of multiple worm wheels. It can be applied to parts processing equipment in the electronics industry ,communication industry and ect..

SDLB 系列精密蜗轮蜗杆减速器 SDLB series high precision worm gear units

优化的接触面

- * 先进的加工技术加上精密的组装，确保齿部的正确啮合，减小齿面的接触应力
- * 特殊研发的蜗轮铜合金，使齿部具有高强度及很好的耐磨性
- * 加上大比率齿面接触，蜗轮不易磨损，能长期保持锁定的侧隙

Optimized contact pattern

- * Advanced processing technology and precision assembly to ensure the correct meshing of the tooth and reduce contact stress of the tooth surface
- * Special worm wheel bronze alloy makes the teeth have high strength and good wear resistance.
- * With a large ratio of tooth surface contact, worm wheel is not easy to wear, it can maintain the locked backlash.

优化的调整结构

- * 能快速设定侧隙
- * 刚性好，精度高
- * 专利结构

Optimized adjustment structure

- * Quickly setting backlash
- * Higher stiffness and precision
- * Patent structure

蜗杆使用圆锥滚子轴承

- * 一端安装两个圆锥滚子轴承，具有更长的使用寿命
- * 消除蜗杆热伸长引起的误差
- * 轴承预紧安装，具有更高的支承刚性

Worm shaft using Taper roller bearings

- * Installed two taper roller bearings with which have longer service lives.
- * Eliminates worm shaft alignment problems
- * Bearing pre-tight installation, with higher support stiffness

免维护

- * 加装高性能全合成润滑油
- * 全封闭结构，无需更换润滑油

Maintenance free

- * High performance synthetic lubricant
- * Closed structure, no need to replace lubricant oil.

能快速安装伺服电机

- * 伺服电机专用高刚性、低惯量联轴器
- * 可提供各种和伺服电机相配的法兰

Quickly install servo motor

- * High stiffness and low inertia coupling for servo motor
- * A variety of flanges can be matched with the servo motor

蜗轮使用加大圆锥滚子轴承

- * 能承受很大的轴向负荷
- * 轴承预紧安装，具有更高的支承刚性

Installed two taper roller bearings with which have longer service lives.

- * Eliminates worm shaft alignment problems
- * Bearing pre-tight installation, with higher support stiffness

提供两种输出背隙

- * 超精密级：1 弧分，适用于要求比较高的场合
- * 精密级：2~4 弧分，品质和价格的折衷方案

Output torsional backlash available in 2 ranges:

- * Ultra precision: 1 arc minute for the most demanding applications
- * Precision: 2 to 4 arc minutes a good compromise price and quality

外壳重力浇铸成形

- * 高强度铝合金浇铸并经过热处理
- * 刚性好，重量轻
- * 外形美观耐候性好

Housing with gravity casting

- * High strength Aluminum Alloy casting and heat treatment
- * Superior rigidity and low weight
- * Beautiful shape and Good weather resisting property

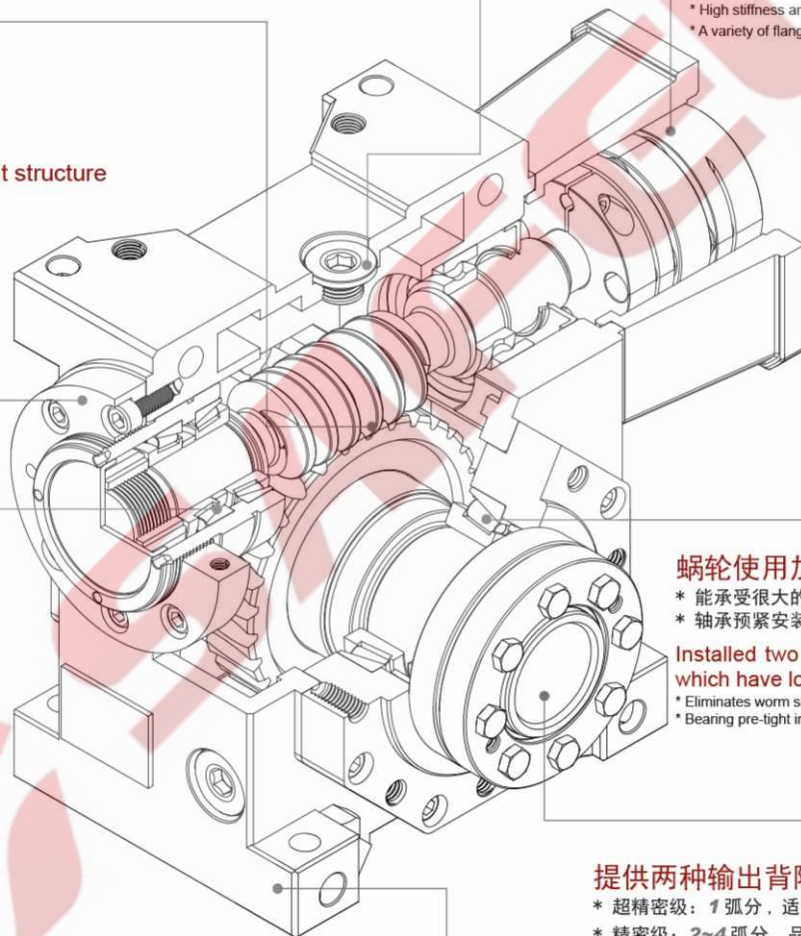

SDLB特点

蜗轮蜗杆伺服减速器有45-50-55-63-75-90六种规格，采用双导程蜗杆传动。蜗杆的左右齿面使用不同的导程角，引起齿厚的渐变，这样就可以移动蜗杆调整啮合间隙。

特点

- 蜗轮回转背隙可以调整到小于1弧分。
- 减速器使用后可以重新调整间隙。
- 输入用联轴器联结：可靠无背隙。
- 输出用锥形夹紧环联轴器：可靠无背隙。

SDLB使用场合

高精度回转运动

- 减少由负载变动及切削力变化等引起的震动及噪音。
- 减少由正反转引起的冲击及噪音。
- 减少由以上引起的蜗轮加剧磨损。
- 增加蜗轮输出的响应速度。

精密分度装置

- 数控机床、流水线、切割机、输送线等。
- 分度装置、读数机构等要求运动准确的场合。

速度有变化的场合

- 减少由速度变化引起的冲击及噪音。
- 减少由速度变化引起的蜗轮加剧磨损。

间隙调整量

SDLB Features

Servo worm gear units have six types :45 - 50 - 55 - 63 - 75 - 90 ,with dual lead worm drive .Left and right flank of worm shaft using different lead angle ,causing tooth thickness gradual change,So that you can move worm shaft and adjust backlash.

Features

- Worm gear gyration backlash can be adjusted to less than 1 arc.
- Reducer can be re-adjusted the gap after using .
- Input with coupling : reliable without backlash .
- Output using conical clamping ring couplings : reliable without backlash.

SDLB Applications

Precision rotary motion

- Reducing the noise and vibration that is caused by the load change and the change of cutting force.
- reducing the noise and impact that is caused by the corotation and reverse.
- By reducing worm abrasion.
- Increasing worm output response speed .

Precision Indexing device

- CNC machine, assembly line, cutting machine, transmission lines, etc.
- Indexing device,accurate reading mechanism require accurate movement occasions .

Speed changing situations

- Reducing the noise and the impact that is caused by speed change.
- Reducing the worm abrasion that is caused by speed changes.

Clearance Adjustment

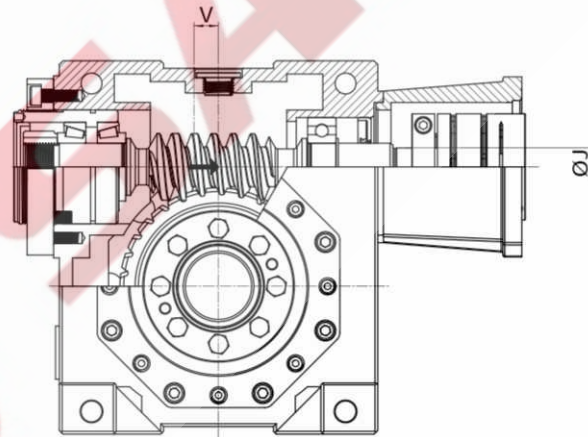

SDLB	调整距离 Adjust the distance	调整量系数 Adjustment coefficient	间隙调整量 Clearance Adjustment	输入轴直径 Input shaft diameter
	V [mm]	k [mm ⁻¹]	ΔS_d [mm]	J [mm]
045	8	0.02-0.04	0.16-0.32	15
050	8	0.015-0.03	0.12-0.24	15
055	8	0.015-0.05	0.12-0.4	18
063	10	0.03-0.05	0.3-0.5	20
075	13	0.03-0.06	0.39-0.78	24
090	13	0.03-0.06	0.39-0.78	28

SDLB 选型

下列的标题包含选择减速器的原理以及正确使用它们的方法。

具体的数值参照相应的章节

1.0 输出扭矩

1.1 额定扭矩 M_{n2} [Nm]

扭矩作用于连续平稳运转的减速器且在工作系数 $f_s = 1$ 的情况下测出的数值。

1.2 需求的扭矩 M_{r2} [Nm]

基于实际所需，数值等于或小于减速器的额定扭矩 M_{n2} 。

1.3 计算扭矩 M_{c2} [Nm]

在选择减速器时有用。
它要考虑实际需求的扭矩 M_{r2} 以及工作系数 f_s ，由以下关系式计算出：

$$M_{c2} = M_{r2} \cdot f_s \leq M_{n2}$$

2.0 功率

2.1 额定输入功率 P_{n1} [kW]

减速器安全运转时的功率(kW)值，列于参数表中。它是在速度等于 n_1 且工作系数 $f_s = 1$ 的情况下得出的。

2.2 额定输出功率 P_{n2} [kW]

减速器的输出功率值，可以用下面的公式计算。

$$P_{n2} = P_{n1} \cdot \eta_d$$

$$P_{n2} = \frac{M_{n2} \cdot n_2}{9550}$$

3.0 效率

效率是影响某些应用的主要因素，它的值基本由齿轮副设计的参数决定。

在第9页上的啮合参数表上记录了动态及静态效率值 ($n_1=1400$)。

注意这些值只适用于磨合完成的在工作温度下运转的减速箱

SDLB Make choice

The following headings contain information on essential elements for selection and correct use of gearbox.

For specific data on the gearbox range, see the relevant chapters.

1.0 OUTPUT TORQUE

1.1 Rated output torque M_{n2} [Nm]

The torque that can be transmitted continuously through the output shaft, with the gear unit operated under a service factor $f_s = 1$.

1.2 Required torque M_{r2} [Nm]

The torque demand based on application requirement. It is recommended to be equal to or less than torque M_{n2} the gearbox under study is rated for.

1.3 Calculated torque M_{c2} [Nm]

Computational torque value to be used when selecting the gearbox. It is calculated considering the required torque M_{r2} and service factor f_s , as per the relationship here after:

2.0 POWER

2.1 Rated input power P_{n1} [kW]

The parameter can be found in the gearbox rating charts and represents the KW that can be safely transmitted to the gearbox, based on input speed n_1 and service factor $f_s = 1$.

2.2 Rated output power P_{n2} [kW]

This value is the power transmitted at gearbox output. it can be calculated with the following formulas:

3.1 动态效率
[η_d]

动态效率和输出功率 P_2 以及输入功率 P_1 的关系:

$$\eta_d = \frac{P_2}{P_1}$$

3.2 静态效率
[η_s]

在减速器刚启动时的效率。虽然对连续传动没有实际的意义，但在选择断续传动的减速器时却十分重要。

4.0 工作系数
[f_s]

减速器的工作系数 (f_s) 主要取决于减速机的运行条件，为了选择最合适的工作环境系数进行正确的组合，必须考虑如下因素:

1. 减速器的负载形式: **A - B - C**
 2. 工作时间: 小时 / 天(Δ)
 3. 开机频率: 次 / 小时(*)
- 负载类型: **A** - 均衡负荷, $f_a \leq 0.3$
B - 中等冲击, $f_a \leq 3$
C - 严重冲击, $f_a \leq 10$

$f_a = J_e / J_m$
 $-J_e(\text{kgm}^2)$: 在驱动轴上衰减的惯性矩
 $-J_m(\text{kgm}^2)$: 电机惯性矩
 -如果 $f_a > 10$ 时请与技术服务部联系

A - 轻质材料螺旋输送机, 风扇, 装配线, 轻质材料皮带输送机, 小型搅拌机, 提升机, 清洁机, 灌装机, 控制器。

B - 卷绕装置, 木工机械, 货物提升机, 平衡器, 螺纹机, 介质搅拌机, 重型材料皮带输送机, 绞盘, 移动门, 刮机, 包装机, 混凝土搅拌机, 起重机械, 磨削机, 卷板机, 齿轮泵。

C - 重型材料搅拌机, 剪切机, 压力机, 离心机, 旋转支撑, 重型材料绞盘和提升机, 磨床, 石材, 升降机, 钻孔机, 锤式粉碎机, 凸轮压力机, 折叠机, 运输带, 翻斗车, 振动器, 撕碎机。

3.1 Dynamic efficiency
[η_d]

The dynamic efficiency is the relationship of power delivered at output shaft P_2 to power applied at input shaft P_1 :

3.2 Static efficiency
[η_s]

Efficiency obtained at start-up of the gearbox. Although this is generally not significant factor for helical gears, it may be instead critical when selecting worm gearmotors operating under intermittent duty.

4.0 SERVICE FACTOR
[f_s]

The service factor (f_s) depends on the operating conditions the gearbox is subjected to the parameters that need to be taken into consideration to select the most adequate service factor correctly comprise:

1. type of load of the operated machine: **A - B - C**
 2. length of daily operating time: **hours/day(Δ)**
 3. start-up frequency: **starts/hour (*)**
- TYPE OF LOAD: **A** - uniform, $f_a \leq 0.3$
B - moderate shocks, $f_a \leq 3$
C - heavy shocks, $f_a \leq 10$

$f_a = J_e / J_m$
 $-J_e(\text{kgm}^2)$ moment of the external inertia reduced at the drive shaft
 $-J_m(\text{kgm}^2)$ moment of inertia of motor
 -If $f_a > 10$ please contact our Technical Service

A -Screw feeders for light materials, fans, assembly lines, conveyor belts for light materials, small mixers, lifts, cleaning machines, fillers, control machines.

B -Winding devices, woodworking machine feeders, goods lifts, balancers,threading machines, medium mixers, conveyor belts for heavy materials,winches, sliding doors, fertilizer scrapers, packing machines, concrete mixers, crane mechanisms, milling cutters, folding machines, gear pumps.

C -Mixers for heavy materials, shears, presses, centrifuges, rotating supports, winches and lifts for heavy materials, grinding lathes, stone mills, bucket elevators, drilling machines, hammer mills, cam presses, folding machines, turntables, tumbling barrels, vibrators, shredders.

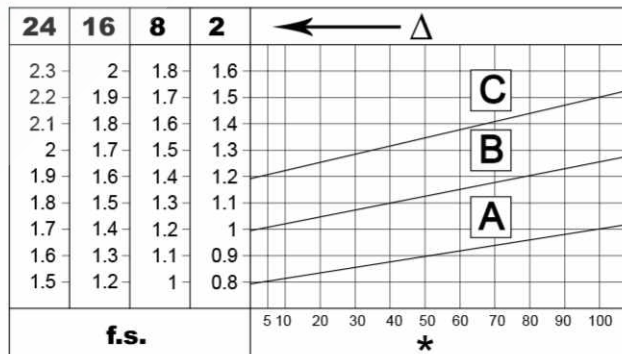

产品名称

DESIGNATION

类型 Type 减速比 Ratio 输出 Output 背隙 Backlash 安装方位 Mounting position 颜色 Color 电机 Electric motor
SDLB075 - 30 - C1 - P0 - B3 - B - 1FK7042...

电机型号 Motor type
1FK7042...

颜色/Color
B = 银灰色/Silver gray O = 橄榄绿/Olive

安装方位/Mounting position (P9)
B3, B6, B7, B8, V5, V6

背隙/Backlash
P0 (超精密/Ultra precision) 1 弧分 (75, 90); 2 弧分 (45, 50, 55, 63)
P1 (精密/Precision) 2~4 弧分

输出轴/Output shaft
C (锁紧盘孔输出/Hollow shaft for shrink disc)
2C (双锁紧盘孔输出/Hollow shaft for double shrink disc)
CR (键槽孔输出/Hollow shaft with keyway)
P (单出轴/Single output shaft)
2P (双出轴/Dual output shaft)
1, 2 (安装位置/Mounting side)

减速比/Reduction ratio
14.5, 19.5, 24.5, 30, 40, 50, 60, 80, 100

减速器尺寸/Gearbox size
45, 50, 55, 63, 75, 90

减速器类型 Reducer type

SDLB 输出方位

SDLB output Position

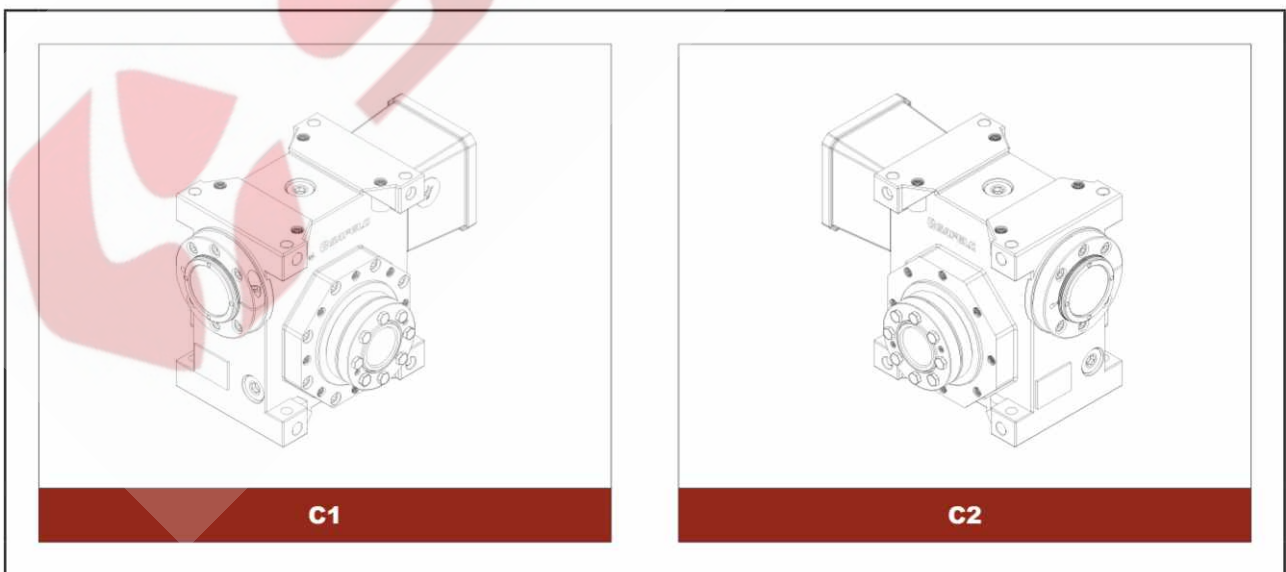

如无特殊说明，锁紧环联轴器安装在C1的位置

The shrink disc is supplied in C1 position, if no special instructions

SDLB 版本

SDLB Versions

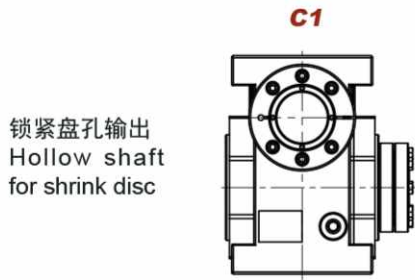

锁紧盘孔输出
Hollow shaft
for shrink disc

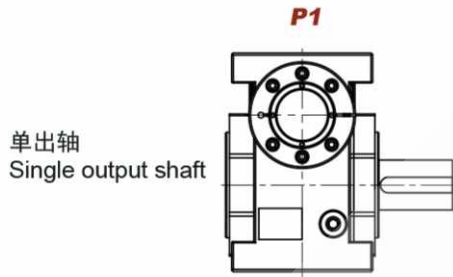
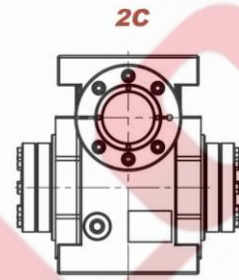
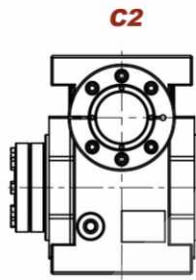

单出轴
Single output shaft

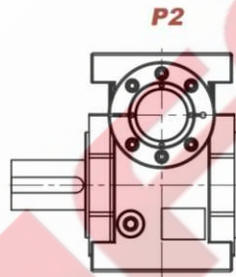

双出轴
Dual output shaft

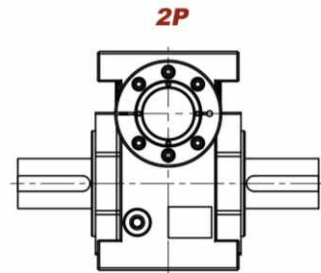

键槽孔输出
Hollow shaft
with keyway

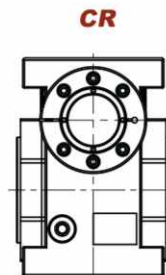

SDLB 啮合参数

SDLB MESH DATA

蜗杆螺旋线、蜗轮齿牙和效率 (n1=1400)

Worm thread, worm wheel tooth and efficiency data (n1=1400)

SDLB	i	14.5	19.5	24.5	30	40	50	60	80	100
045	Z ₁	2	2	2	1	1	1	1		
	γ	14°06'	11°33'	9°44'	7°10'	5°50'	4°54'	4°14'		
	M _x	2.35	1.8	1.45	2.35	1.8	1.45	1.22		
	η _d	0.80	0.77	0.74	0.69	0.64	0.61	0.57		
	η _s	0.58	0.53	0.5	0.44	0.4	0.36	0.32		
050	Z ₁	2	2	2	1	1	1	1		
	γ	11°18'	9°04'	7°36'	5°42'	4°33'	3°49'	3°17'		
	M _x	2.5	1.9	1.54	2.5	1.9	1.54	1.3		
	η _d	0.8	0.77	0.74	0.7	0.65	0.61	0.57		
	η _s	0.58	0.54	0.5	0.44	0.39	0.35	0.32		
055	Z ₁	2	2	2	1	1	1	1	1	
	γ	12°20'	10°02'	8°23'	6°14'	5°03'	4°13'	3°37'	2°48'	
	M _x	2.8	2.15	1.73	2.8	2.15	1.73	1.45	1.09	
	η _d	0.81	0.78	0.75	0.71	0.66	0.62	0.58	0.53	
	η _s	0.58	0.54	0.5	0.44	0.39	0.35	0.32	0.27	
063	Z ₁	2	2	2	1	1	1	1		
	γ	12°50'	10°29'	8°44'	6°30'	5°17'	4°23'	3°47'		
	M _x	3.25	2.5	2	3.25	2.5	2	1.68		
	η _d	0.82	0.8	0.77	0.73	0.69	0.65	0.61		
	η _s	0.59	0.54	0.5	0.45	0.4	0.36	0.33		
075	Z ₁	2	2	2	1	1	1	1	1	
	γ	14°02'	11°18'	9°37'	7°07'	5°42'	4°50'	4°05'	3°15'	
	M _x	4	3	2.45	4	3	2.45	2	1.54	
	η _d	0.84	0.81	0.79	0.75	0.71	0.68	0.64	0.59	
	η _s	0.6	0.57	0.52	0.46	0.42	0.38	0.35	0.29	
090	Z ₁	2	2	2	1	1	1	1	1	1
	γ	15°05'	12°14'	10°37'	7°40'	6°11'	5°21'	4°36'	3°36'	2°57'
	M _x	4.8	3.6	3	4.8	3.6	3	2.5	1.88	1.5
	η _d	0.85	0.83	0.81	0.77	0.74	0.71	0.68	0.62	0.58
	η _s	0.63	0.59	0.55	0.49	0.45	0.41	0.38	0.32	0.28

SDLB 安装方位

SDLB Mounting positions

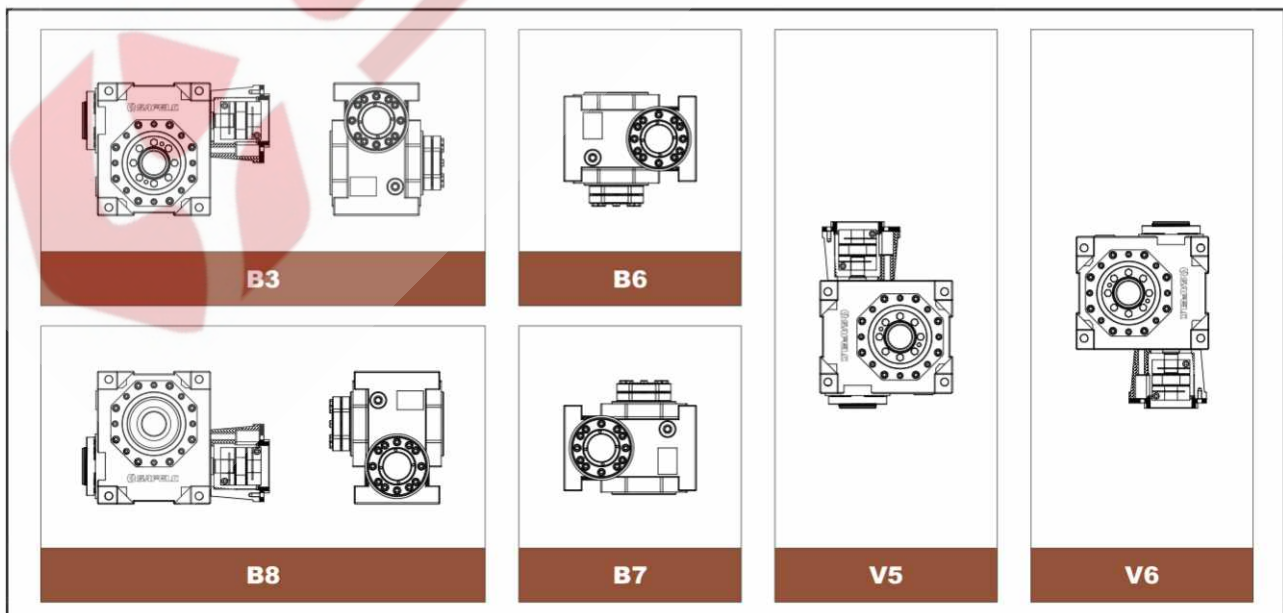

SDLB 性能参数

SDLB Performance

n1		3000					1400					900				
SDLB	i	η_d Effi.	P ₁ [kW]	M ₂ [Nm]	n ₂ [min ⁻¹]	η_d Effi.	P ₁ [kW]	M ₂ [Nm]	n ₂ [min ⁻¹]	η_d Effi.	P ₁ [kW]	M ₂ [Nm]	n ₂ [min ⁻¹]	Fr ₂ [N]	Fa ₂ [N]	
045	14.5	0.85	1.1	44	206.9	0.80	0.6	52	96.6	0.74	0.5	58	62.1	5500	3800	
	19.5	0.82	0.9	46	153.8	0.77	0.5	54	71.8	0.71	0.4	60	46.2	5500	3800	
	24.5	0.79	0.7	47	122.4	0.74	0.4	55	57.1	0.68	0.3	61	36.7	5500	3800	
	30	0.74	0.7	52	100	0.69	0.4	61	46.7	0.63	0.3	67	30	5500	3800	
	40	0.69	0.6	49	75	0.64	0.3	57	35.0	0.58	0.3	62	22.5	5500	3800	
	50	0.66	0.5	50	60	0.61	0.3	58	28.0	0.55	0.2	63	18	5500	3800	
60	0.62	0.4	49	50	0.57	0.2	57	23.3	0.51	0.2	62	15	5500	3800		
050	14.5	0.85	1.4	57	206.9	0.80	0.9	74	96.6	0.74	0.7	84	62.1	5500	3800	
	19.5	0.82	1.0	53	153.8	0.77	0.7	73	71.8	0.71	0.5	77	46.2	5500	3800	
	24.5	0.79	0.8	51	122.4	0.74	0.6	70	57.1	0.68	0.4	75	36.7	5500	3800	
	30	0.75	0.9	64	100	0.70	0.6	84	46.7	0.64	0.4	90	30	5500	3800	
	40	0.7	0.7	59	75	0.65	0.4	76	35.0	0.59	0.3	82	22.5	5500	3800	
	50	0.66	0.5	53	60	0.61	0.4	73	28.0	0.55	0.3	77	18	5500	3800	
60	0.62	0.4	50	50	0.57	0.3	68	23.3	0.51	0.2	72	15	5500	3800		
055	14.5	0.86	2.1	85	206.9	0.81	1.2	101	96.6	0.75	0.9	112	62.1	6700	4600	
	19.5	0.83	1.7	88	153.8	0.78	1.0	105	71.8	0.72	0.8	116	46.2	6700	4600	
	24.5	0.8	1.4	92	122.4	0.75	0.8	108	57.1	0.69	0.7	120	36.7	6700	4600	
	30	0.76	1.4	100	100	0.71	0.8	118	46.7	0.65	0.6	130	30	6700	4600	
	40	0.71	1.0	94	75	0.66	0.6	111	35.0	0.6	0.5	121	22.5	6700	4600	
	50	0.67	0.9	92	60	0.62	0.5	108	28.0	0.56	0.4	117	18	6700	4600	
60	0.63	0.8	94	50	0.58	0.5	110	23.3	0.52	0.4	119	15	6700	4600		
80	0.58	0.6	88	37.5	0.53	0.4	102	17.5	0.47	0.3	109	11.3	6700	4600		
063	14.5	0.87	2.5	103	206.9	0.82	1.7	140	96.6	0.76	1.3	155	62.1	8400	8100	
	19.5	0.85	1.8	100	153.8	0.80	1.2	135	71.8	0.74	0.9	148	46.2	8400	8100	
	24.5	0.82	1.4	92	122.4	0.77	1.0	130	57.1	0.71	0.7	137	36.7	8400	8100	
	30	0.78	1.6	120	100	0.73	1.1	160	46.7	0.67	0.8	175	30	8400	8100	
	40	0.74	1.1	108	75	0.69	0.8	145	35.0	0.63	0.6	160	22.5	8400	8100	
	50	0.7	0.9	100	60	0.65	0.6	135	28.0	0.59	0.5	145	18	8400	8100	
60	0.67	0.7	95	50	0.62	0.5	130	23.3	0.56	0.4	138	15	8400	8100		
075	14.5	0.89	3.5	150	206.9	0.84	2.3	200	96.6	0.78	1.9	235	62.1	10000	10000	
	19.5	0.86	2.9	160	153.8	0.81	1.9	210	71.8	0.75	1.5	235	46.2	10000	10000	
	24.5	0.84	2.2	150	122.4	0.79	1.5	200	57.1	0.73	1.1	215	36.7	10000	10000	
	30	0.8	2.2	170	100	0.75	1.5	230	46.7	0.69	1.2	260	30	10000	10000	
	40	0.76	1.7	165	75	0.71	1.1	220	35.0	0.65	0.9	240	22.5	10000	10000	
	50	0.73	1.3	150	60	0.68	0.9	210	28.0	0.62	0.7	220	18	10000	10000	
60	0.69	1.1	145	50	0.64	0.8	200	23.3	0.58	0.6	210	15	10000	10000		
80	0.64	0.8	130	37.5	0.59	0.6	190	17.5	0.53	0.4	200	11.3	10000	10000		
090	14.5	0.9	6.3	270	206.9	0.85	4.1	360	96.6	0.79	3.3	420	62.1	15000	12300	
	19.5	0.88	4.6	260	153.8	0.83	3.1	355	71.8	0.77	2.4	390	46.2	15000	12300	
	24.5	0.86	3.7	250	122.4	0.81	2.5	340	57.1	0.75	1.9	370	36.7	15000	12300	
	30	0.82	4.0	310	100	0.77	2.6	410	46.7	0.71	2.0	460	30	15000	12300	
	40	0.79	2.7	275	75	0.74	1.8	360	35.0	0.68	1.4	410	22.5	15000	12300	
	50	0.76	2.2	265	60	0.71	1.4	340	28.0	0.65	1.1	390	18	15000	12300	
60	0.73	1.8	245	50	0.68	1.1	320	23.3	0.62	0.9	350	15	15000	12300		
80	0.67	1.3	225	37.5	0.62	0.8	285	17.5	0.56	0.7	315	11.3	15000	12300		
100	0.63	1.0	200	30	0.58	0.7	270	14.0	0.52	0.5	280	9	15000	12300		

SDLB 系列尺寸图

SDLB Series dimensions charts

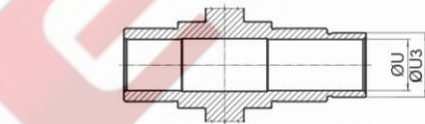
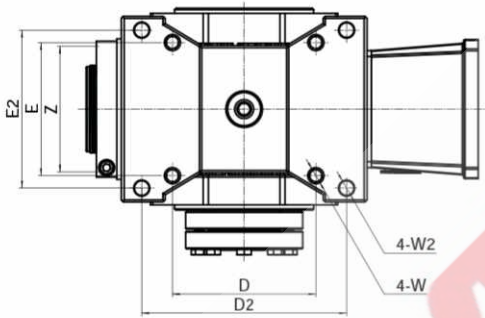
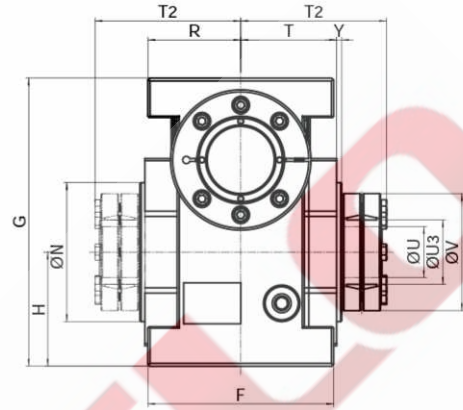
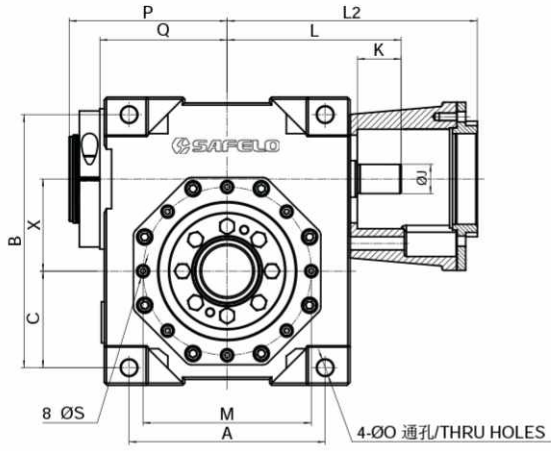

锁紧盘孔输出/Hollow Output Bore With Shrink disc

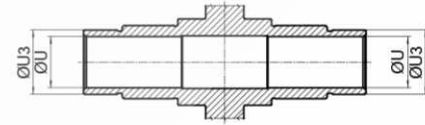

双锁紧盘孔输出/Hollow Output Bore With double Shrink disc

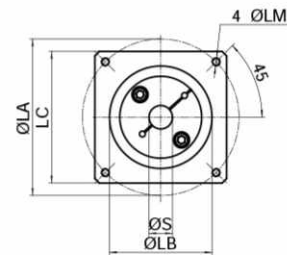
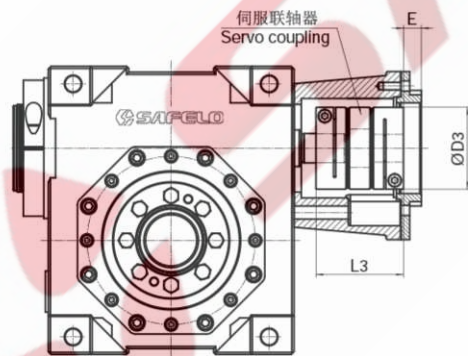

伺服电机示意图/Servo motor

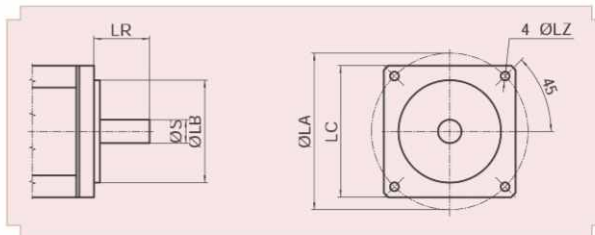

SDLB	045	050	055	063	075	090
A	108	108	120	134	172	186
B	135	138	155	173	208	234
C	53	53	61	66	82	91
D	81	81	90	98	136	141
D2	114	114	125	140	172	204
D3	44	44	56	56	68	68
E	68	68	78	91	110	130
E2	84	84	96	108	125	140
E3	5	5	6.5	6.5	6.5	6.5
F	100	100	112	127	148	170
G	153	156	175	197	232	264
H	62	62	71	78	94	106
J(h6)	15	15	18	20	24	28
K	24	24	28	30	35	35
L	98.5	98.5	111	122	147	157
L2	103+LR	103+LR	116+LR	127+LR	152+LR	162+LR
L3	48	48	59.8	59.8	73.3	73.3
M	85	85	100	115	130	165
N(h7)	70	70	80	95	110	130
O	9	9	9	11	11	13
P(max)	91	91	100	108	129	139.5
Q	70.5	70.5	78	87	107	117.5
R	50	50	56	63.5	74	85
S	M8	M8	M8	M8	M10	M12
T	52	52	58	65.5	76	87
T2	78	78	87	96.5	110	124
U(H7)	25	25	30	35	40	50
U3	30	30	36	44	50	68
V	60	60	72	80	90	115
W	M8	M8	M8	M10	M10	M12
W2	9	9	9	10	12	14
X	45	50	55	63	75	90
Y	3	3	3.5	3.5	4	4
Z	86	86	86	93	108	108
LA/LB/LC/LR/LM/S	按伺服电机 /By servo motor					

SDLB 系列尺寸图

SDLB Series dimensions charts

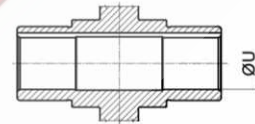
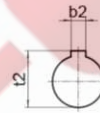
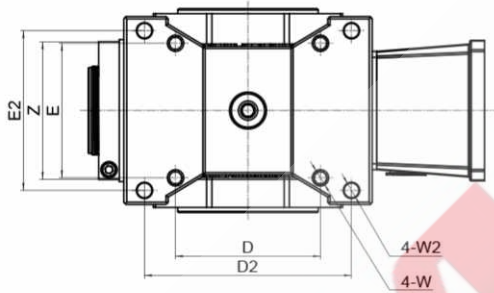
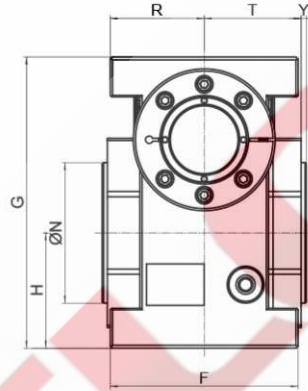
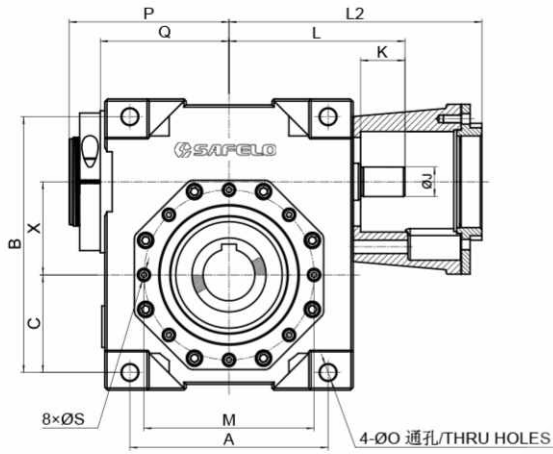

带键孔输出/Hollow Output Bore With Keyway

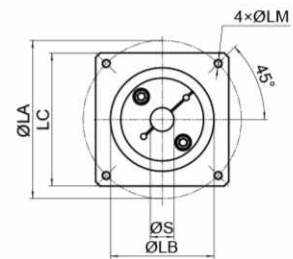
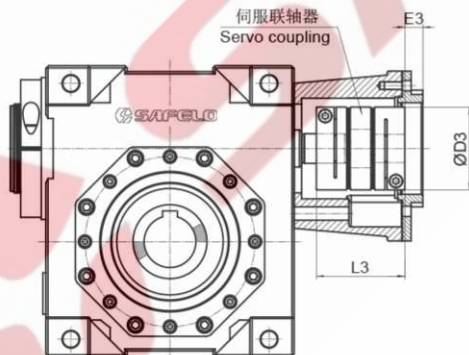

伺服电机示意图/Servo motor

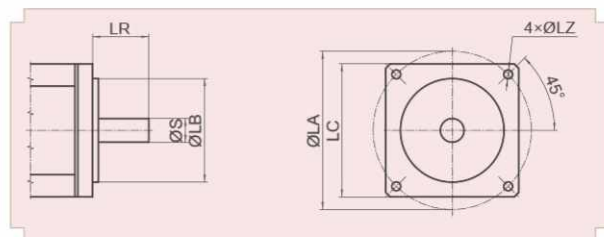

SDLB	045	050	055	063	075	090
A	108	108	120	134	172	186
B	135	138	155	173	208	234
C	53	53	61	66	82	91
D	81	81	90	98	136	141
D2	114	114	125	140	172	204
D3	44	44	56	56	68	68
E	68	68	78	91	110	130
E2	84	84	96	108	125	140
E3	5	5	6.5	6.5	6.5	6.5
F	100	100	112	127	148	170
G	153	156	175	197	232	264
H	62	62	71	78	94	106
J(h6)	15	15	18	20	24	28
K	24	24	28	30	35	35
L	98.5	98.5	111	122	147	157
L2	103+LR	103+LR	116+LR	127+LR	152+LR	162+LR
L3	48	48	59.8	59.8	73.3	73.3
M	85	85	100	115	130	165
N	70	70	80	95	110	130
O	9	9	9	11	11	13
P	91	91	100	108	129	139.5
Q	70.5	70.5	78	87	107	117.5
R	50	50	56	63.5	74	85
S	M8	M8	M8	M8	M10	M12
T	52	52	58	65.5	76	87
U(H7)	25	25	30	35	40	50
V	60	60	72	80	90	115
W	M8	M8	M8	M10	M10	M12
W2	9	9	9	10	12	14
X	45	50	55	63	75	90
Y	3	3	3.5	3.5	4	4
Z	86	86	86	93	108	108
t2	28.3	28.3	33.3	38.3	43.3	53.8
b2	8	8	8	10	12	14
LA/LB/LC/LR/LM/S	按伺服电机 /By servo motor					

SDLB 系列尺寸图

SDLB Series dimensions charts

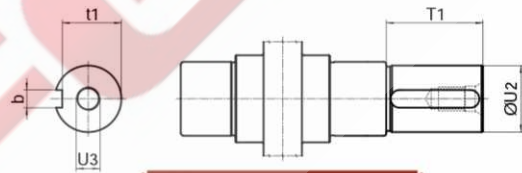
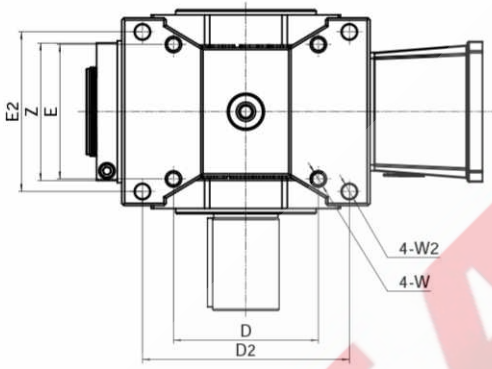
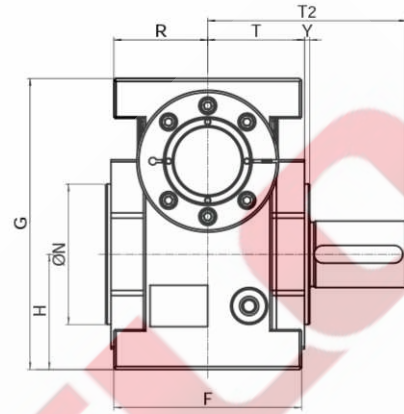
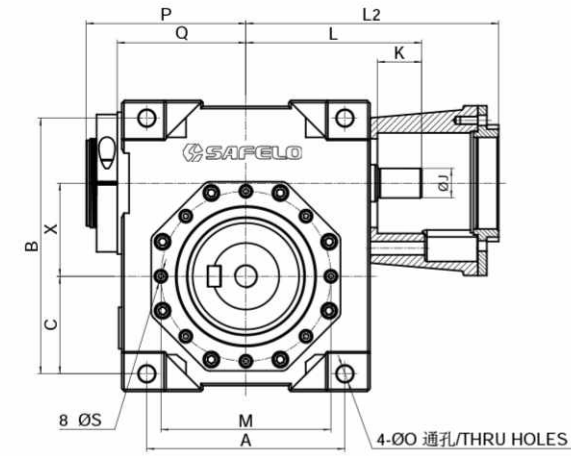

单输出轴/Single output shaft

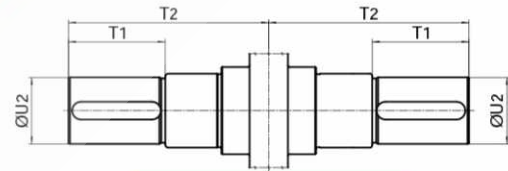

双输出轴/Double output shaft

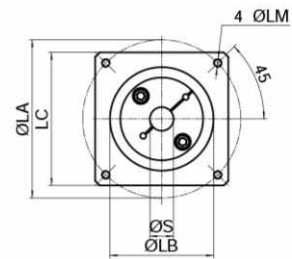
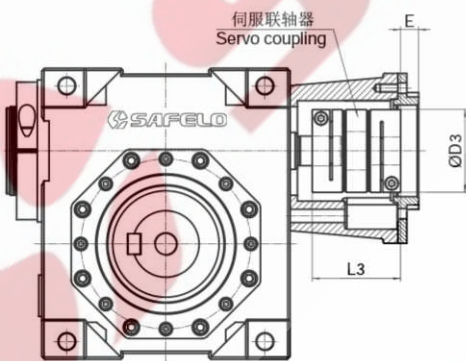

伺服电机示意图/Servo motor

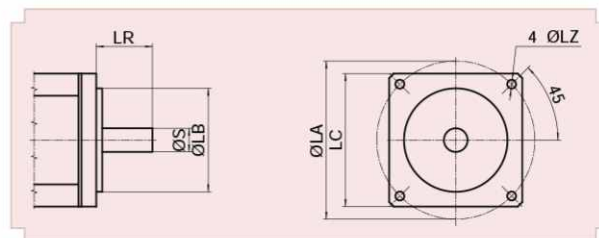

SDLB	045	050	055	063	075	090
A	108	108	120	134	172	186
B	135	138	155	173	208	234
C	53	53	61	66	82	91
D	81	81	90	98	136	141
D2	114	114	125	140	172	204
D3	44	44	56	56	68	68
E	68	68	78	91	110	130
E2	84	84	96	108	125	140
E3	5	5	6.5	6.5	6.5	6.5
F	100	100	112	127	148	170
G	153	156	175	197	232	264
H	62	62	71	78	94	106
J(h6)	15	15	18	20	24	28
K	24	24	28	30	35	35
L	98.5	98.5	111	122	147	157
L2	103+LR	103+LR	116+LR	127+LR	152+LR	162+LR
L3	48	48	59.8	59.8	73.3	73.3
M	85	85	100	115	130	165
N	70	70	80	95	110	130
O	9	9	9	11	11	13
P	91	91	100	108	129	139.5
Q	70.5	70.5	78	87	107	117.5
R	50	50	56	63.5	74	85
S	M8	M8	M8	M8	M10	M12
T	52	52	58	65.5	76	87
T1	55	55	60	70	75	100
T2	110	110	121.5	139	155	191
U2(h6)	35	35	40	45	50	65
U3	M12	M12	M16	M16	M16	M20
V	60	60	72	80	90	115
W	M8	M8	M8	M10	M10	M12
W2	9	9	9	10	12	14
X	45	50	55	63	75	90
Y	3	3	3.5	3.5	4	4
Z	86	86	86	93	108	108
t1	30	30	35	39.5	44.5	58
b	10	10	12	14	14	18
LA/LB/LC/LR/LM/S	按伺服电机 /By servo motor					

参数符号对应表

符号 Symbols	单位 Units	注解
P	[kW]	功率
P₁	[kW]	输入功率
P₂	[kW]	输出功率
P_{n1}	[kW]	额定输入功率
M₂	Nm	输出扭矩
M_{c2}	Nm	计算的输出扭矩
M_{n2}	Nm	额定输出扭矩
M_{r2}	Nm	需求的扭矩
n₁	min ⁻¹	输入转速
n₂	min ⁻¹	输出转速
i	-	减速比
η_d	-	动态效率
η_s	-	静态效率
Z₁	-	蜗杆齿数
M_x	-	轴向模数
f_s	-	工作系数
J_e	kgm ²	在电机轴上衰减的惯性矩
J_m	kgm ²	电机惯性矩
F_{r1}	N	输入轴径向负荷
F_{r2}	N	输出轴径向负荷
F_{a2}	N	输出轴轴向负荷

SYMBOLS AND UNITS OF MEASURE

Description
Power
Transmitted power at input shaft
Transmitted power at output shaft
Rated input power
Transmitted torque at output shaft
Calculated torque at output shaft
Rated torque at output shaft
Required torque at output shaft
Angular input speed
Angular output speed
Ratio
Dynamic efficiency
Static efficiency
Number of worm thread
Axial modulus
Service factor
Moment of the external inertia reduced at the drive shaft
Moment of inertia of motor
Input shaft radial load
Output shaft radial load
Output shaft axial load



Operation Manual 操作手册

SDLB 系列精密蜗轮蜗杆减速器
SDLB SERIES HIGH PRECISION WORM GEAR UNIRTS

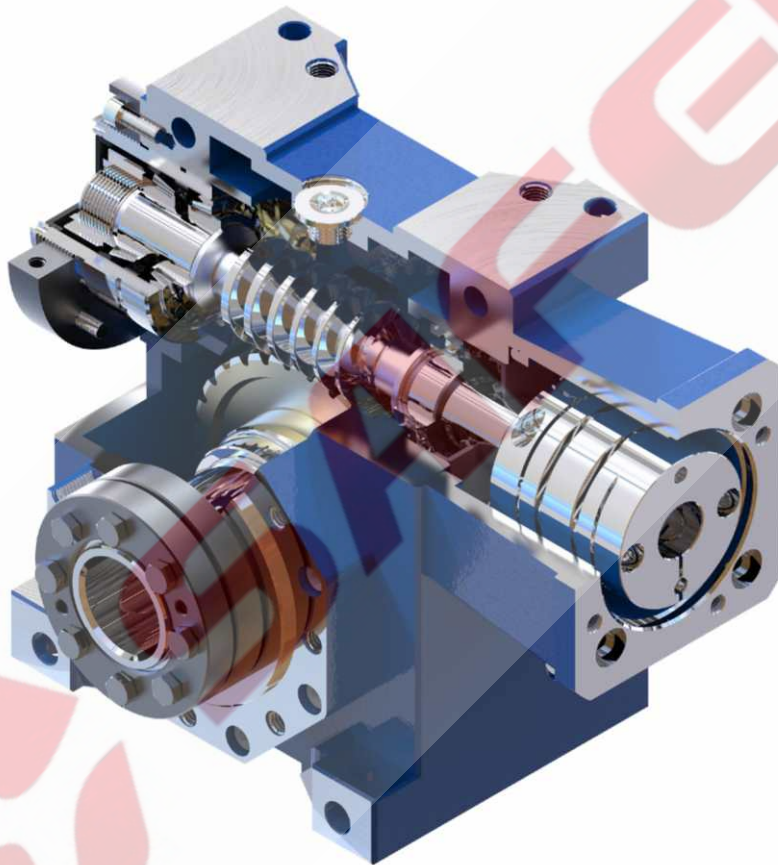

回转背隙调整说明
BACKLASH ADJUSTING AND
OPERATING INSTRUCTIONS

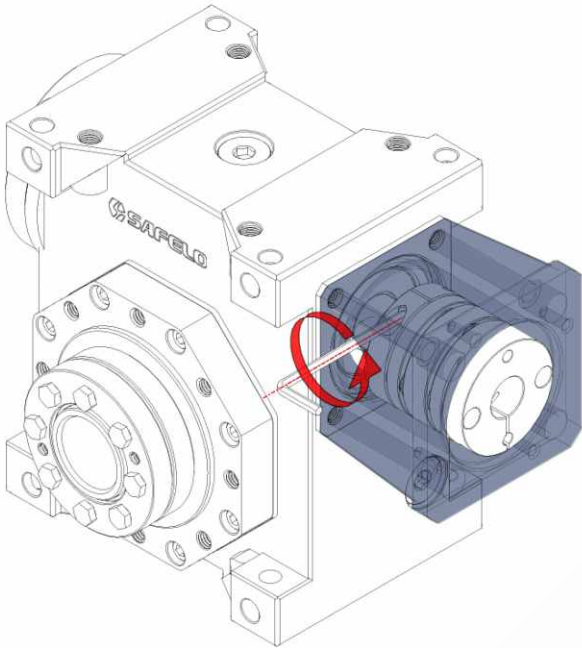

1. 松开联轴器夹紧螺钉，若没有安装电机时可省略此步骤

Loosen the clamping screw on the coupling, skip this step if the motor is not installed

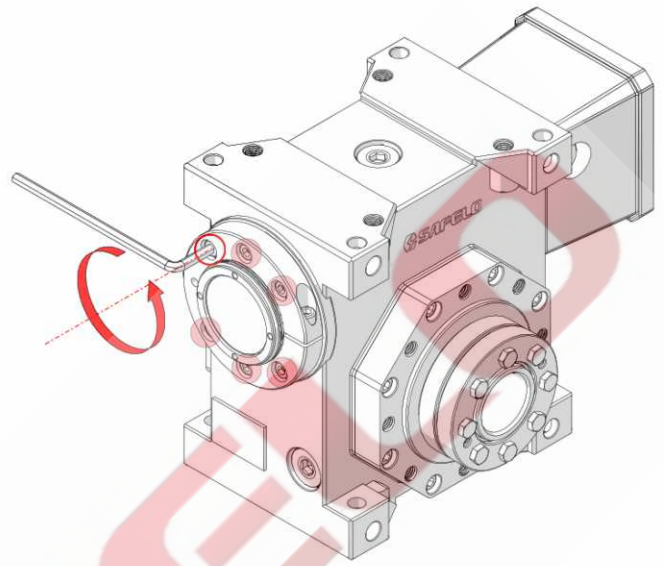

2. 松开锁紧座上的六个固定螺钉（刚好能轻松转动即可，不要拧出太多）

Loosen the six setscrews on the locking seat (just enough to rotate easily)

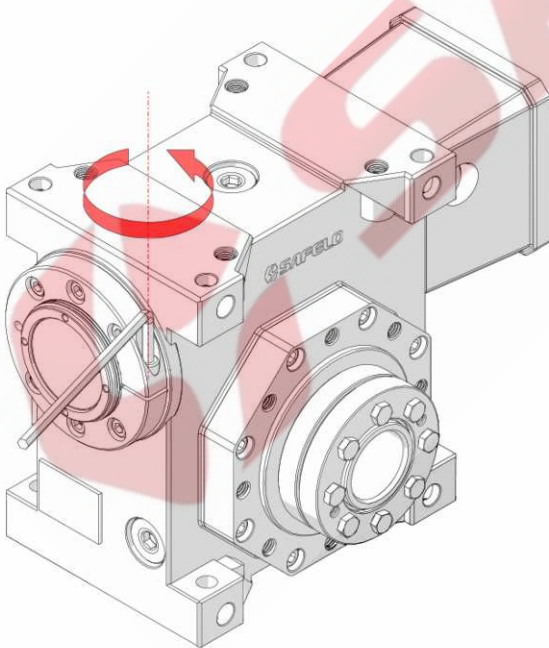

3. 松开锁紧座上的夹紧螺钉

Loosen the clamping screw on the locking seat

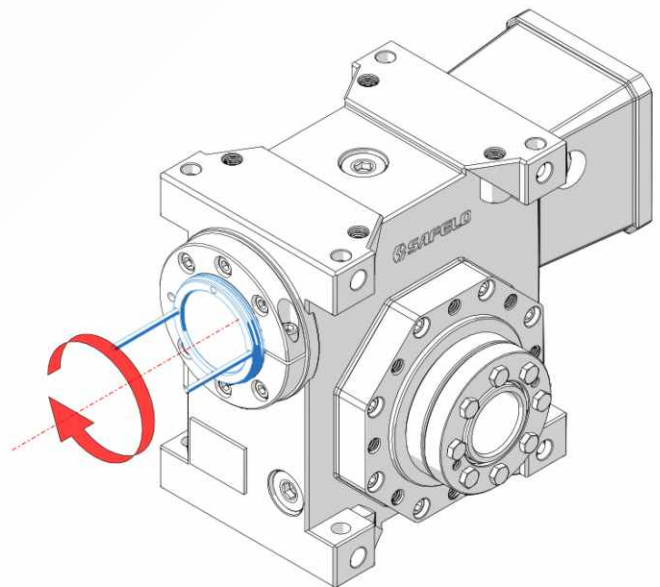

4. 顺时针转动调整螺母

Turn the adjusting nut clockwise

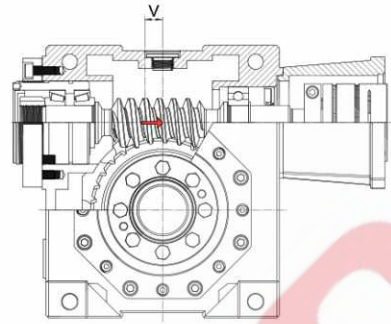
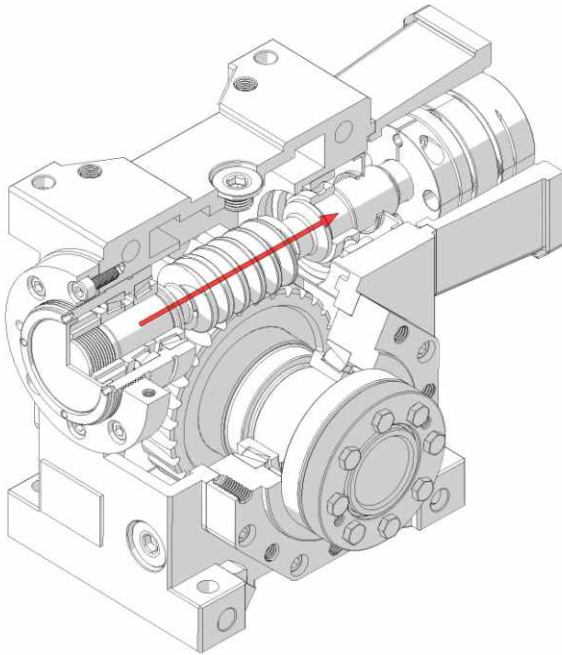

SDLB	调整距离	调整量系数	间隙调整量
	Adjust the distance	Adjustment coefficient	Clearance Adjustment
	V	k	ΔS_d
	[mm]	[mm ⁻¹]	[mm]
045	8	0.02-0.04	0.16-0.32
050	8	0.015-0.03	0.12-0.24
055	8	0.015-0.05	0.12-0.4
063	10	0.03-0.05	0.3-0.5
075	13	0.03-0.06	0.39-0.78
090	13	0.03-0.06	0.39-0.78

5. 通过转动调整螺母推动蜗杆向右移动，从而实现调整背隙的目的

Push the worm to the right by turning the adjusting nut, thereby realize the purpose of clearance adjustment

6. 背隙调整范围

Range of clearance adjustment

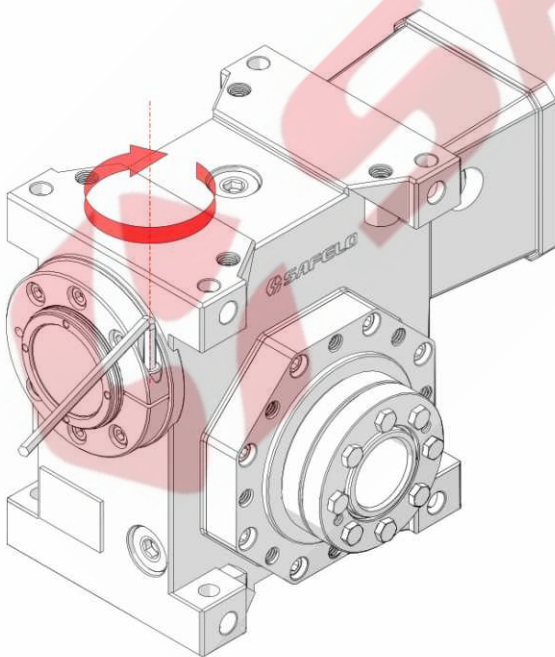

7. 背隙调整到合适的数值后，拧紧锁紧座上的夹紧螺钉

Adjust the backlash to the appropriate value and tighten up the clamping screw

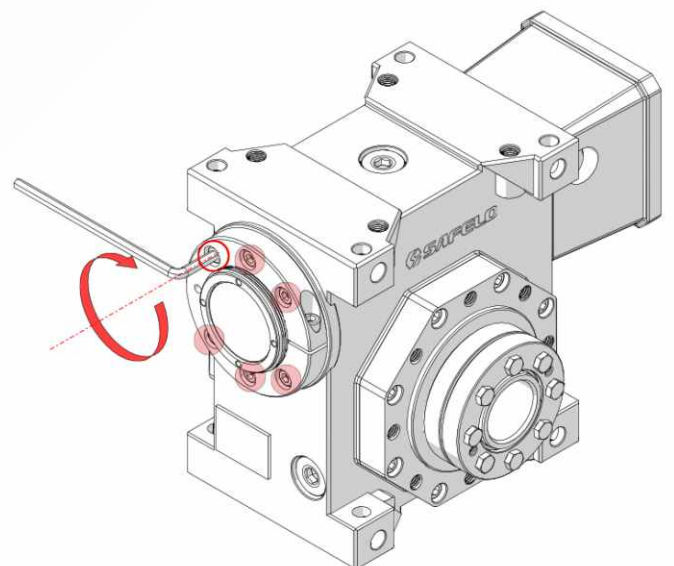

8. 拧紧锁紧座上的六个固定螺钉（需交叉拧紧）

Tighten up the six setscrews (tighten screws alternately)



上海塞弗勒减速机有限公司

地址：上海市金山区亭卫公路1500号
电话：021-56613070 021-56613150
网址：www.cn-safelo.com

SHANGHAI SAFELO DRIVE CO.,LTD.

ADD: 1500 Tingwei Road, Jinshan District, Shanghai
TEL: 021-56613070 021-56613150
www.cn-safelo.com

